

Qualtek Electronics Corporation

P
PC

 Primary Power Components Division

POWER SUPPLIES

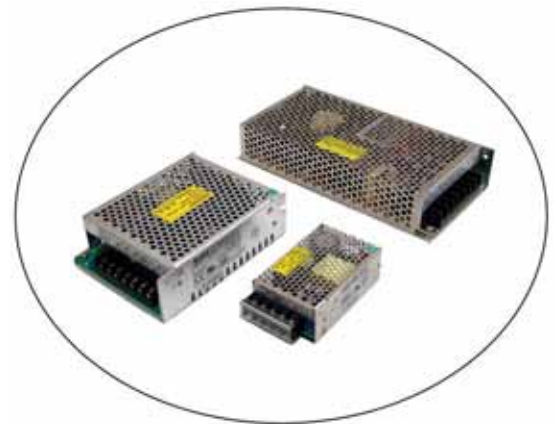
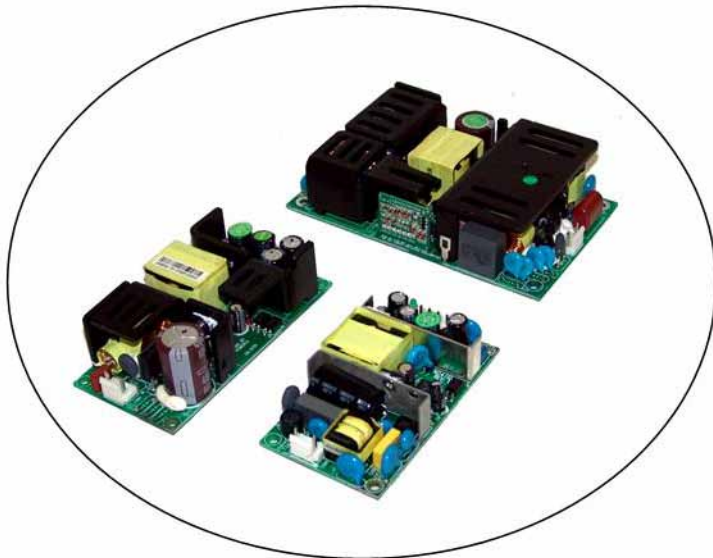

ISO 9001:200G
FS 515889

www.qualtekusa.com



Qualtek offers a wide range of AC/DC, DC/DC converters, and LED power supplies. Qualtek power supplies are available in enclosed frame, open frame, L bracket, U bracket, external desktop, wall mounted, on board module, and din rail. Our power supplies are offered in compact designs to comply with safety agency regulations and are available with power factor correction and multiple outputs.

ENCLOSED FRAME SWITCHING POWER SUPPLIES

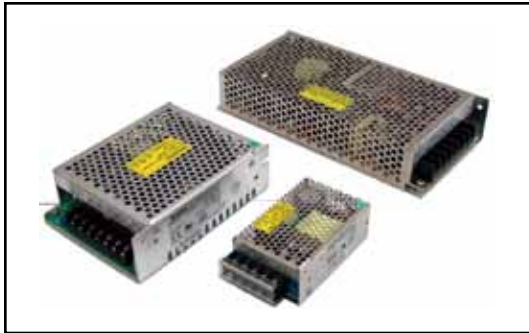

Features:

- Universal AC input / Full Range (except QPD-150)*
- High Efficiency and High Reliability
- Output Protections: OLP/OVP/SCP
- Wide Operating Ambient Temperature (-20°C ~ 70°C)
- All using 105°C Long Life Electrolytic Capacitors
- 100% Full Load Burn-In Test

**RoHS
Compliant**

Part Number	Output Power	Input Voltage	# of Outputs	Output Voltage	Power Factor Correction	Dimensions	Approvals
QPD-15	15W	88-264VAC	1	3.3, 5, 12, 15, 24	-	79 x 51 x 28	CE CB c UL US
QPD-25	25W	88-264VAC	1	3.3, 5, 12, 15, 24	-	79 x 51 x 28	CE CB c UL US
QPD-60	60W	88-264VAC	1	5, 12, 15, 24, 48	-	129 x 98 x 38	CE c UL US
QPD-100	100W	88-264VAC	1	5, 12, 15, 24, 48	-	160 x 98 x 38	CE
QPD-150	150W	88-264VAC	1	5, 12, 15, 24, 48	-	199 x 98 x 38	CE c UL US

* QPD-150 AC Input Selectable by Switch (115VAC/230VAC)



Features:

- Universal AC input / Full Range
- Built-In Active PFC Function, PF>0.93
- High Efficiency and High Reliability
- Output Protections: OLP/OVP/SCP
- Wide Operating Ambient Temperature (-10°C ~ 60°C) (Except QPDF-320)*
- All using 105°C Long Life Electrolytic Capacitors
- 100% Full Load Burn-In Test

**RoHS
Compliant**

Part Number	Output Power	Input Voltage	# of Outputs	Output Voltage	Power Factor Correction	Dimensions	Approvals
QPDF-100	100W	85-264VAC	1	5, 12, 15, 24, 48	✓	194 x 99 x 80	CE CB c UL US
QPDF-150	150W	85-264VAC	1	5, 12, 15, 24, 36, 48	✓	194 x 99 x 80	CE CB c UL US
QPDF-200	200W	85-264VAC	1	5, 12, 15, 24, 48	✓	199 x 99 x 50	CE
QPDF-320	320W	88-264VAC	1	3.3, 5, 7.5, 12, 24, 32, 36, 48	✓	226.5 x 115 x 50	CE CB c UL US
QGPF-U500S	500W	90-264VAC	1	12, 15, 24, 27.5, 48	✓	170 x 117 x 94	CE

* QPDF-320 Operating Ambient Temperature (-20°C ~ 65°C)

OPEN FRAME SWITCHING POWER SUPPLIES



Features:

- Universal AC input / Full Range
- High Efficiency and High Reliability
- Output Protections: OLP/OVP/SCP
- Wide Operating Ambient Temperature (-20°C ~ 60°C)
(Except QPS-60)*
- All using 105°C Long Life Electrolytic Capacitors
- 100% Full Load Burn-In Test

**RoHS
Compliant**

Part Number	Output Power	Input Voltage	# of Outputs	Output Voltage	Power Factor Correction	Dimensions	Approvals
QPS-20	20W	85-264VAC	1	5, 12, 15, 24, 48	-	89 x 51 x 20	CE CB cULUS
QPS-60	60W	90-264VAC	1	3.3, 5, 12, 15, 24, 48	-	101.6 x 50.8 x 28	CE CB cULUS
QPSF-125	125W	90-264VAC	1	5, 12, 15, 24, 28, 48	✓	127 x 76 x 30.5	CE CB cULUS

* QPS-60 Operating Ambient Temperature (-20°C ~ 70°C)

DC/DC INSULATED MODULE POWER SUPPLIES



Features:

- Approval to IEC/EN 60950, Safety Standards
- Wide Input Voltage 36VDC - 75VDC
- Wide Operating Ambient Temperature (-40°C ~ 55°C)
- Remote Control
- No Minimum Load Requirements

**RoHS
Compliant**

Part Number	Output Power	Input Voltage	# of Outputs	Output Voltage	Power Factor Correction	Dimensions	Approvals
QPDD10-48D	10W	36 - 75VDC	2	±5, ±12, ±15	-	50.8 x 25.4 x 10.16	cULUS
QPDD10-48S	10W	36 - 75VDC	1	3.3, 5, 12, 15	-	50.8 x 25.4 x 10.16	cULUS
QPDS15-48S	15W	36 - 75VDC	1	3.3, 5, 12, 15	-	41.9 x 37.1 x 10.16	cULUS

DIN RAIL ACCESSORY KIT

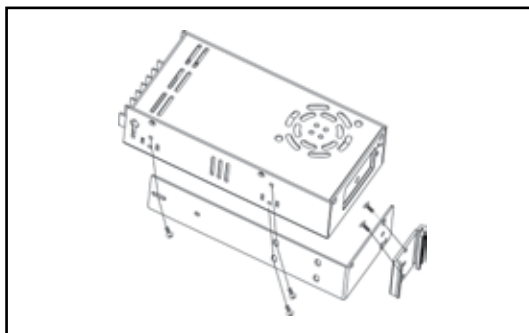

Power Supply	Din Rail	Power Supply	Din Rail	Power Supply	Din Rail
QPD-15	LA+CD-A	QPD-100	LB+CD-A	QPDF-320	LC+CD-A
QPD-25	LA+CD-A	QPD-150	LB+CD-A	QGPF-U500S	LC+CD-A
QPD-60	LA+CD-A	QPDF-200	LB+CD-A		

* Kit consists of Mounting Bracket, Din Rail and Screws

**RoHS
Compliant**

Product Profile



AC Receptacles

Primary Power Components Division

A complete line of inlets, outlets, multifunction modules, circuit breakers, voltage selector switches and switches have the major international approval marks thus assuring high safety standards. Our Power Components help customers comply with international regulations. Modern production methods enable us to manufacture cost-effective and reliable components. A full range of products are maintained in inventory for quick on-time deliveries. Custom designs are available upon request.



Cable Assemblies

Wire, Cable & Interconnect Division

Offering a complete range of new designs and configurations to its extensive line of cable assembly products. Products include Adapters, Flat Ribbon Cable, IEEE Cables, DVI, HDMI, USB, Monitor Cables, OEM Cables and Networking Cables.



EMI Power Line Filters

Primary Power Components Division

EMI/RFI power line filters are designed to meet most international safety agency requirements. These filters help customers meet FCC and VDE emission standards. Our line consists of many standard configurations such as block type, filter with power line connector, and various filters with multifunctional modules. Custom designs are available upon request.



AC & DC Fans

Fan-S Division

Qualtek Electronics offers a complete line of low cost AC & DC axial fans produced in high tech facilities assuring high quality standards with large production capabilities. Qualtek's AC and DC fans are offered in a large variety of bearing types: 2-Ball, 1-Ball 1-Sleeve, Sleeve, and Hydro Dynamic with a wide range of speeds. AC fans are available from 115 to 230VAC and sizes from 60mm to 280mm, DC fans from are available from 3.3-60VDC and sizes from 20mm to 254mm with a large array of functions and special features.

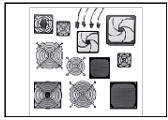

Fan Accessories

Fan-S Division

A complete line of accessories for tubeaxial fans consisting of wire form fan guards, plastic fan guards, plastic fan filter assemblies, aluminum fan filters and fan power cords with excellent quality and competitive prices. Our accessories are designed to comply with international safety agency regulations to insure a safe and durable product. Custom designs are available upon request.



Heat Shrink Products

Wire, Cable & Interconnect Division

Heat shrinkable products include: Polyolefin, Silicon, Fiberglass, Teflon, Viton®, Kynar®, Halogen-Free and high temp tubing. It is available in different sizes, colors and materials. Qualtek heat shrink tubing products are produced by cross-linking extruded polymer compounds which produces a shape memory effect and when heated, can be recovered into its original shape.



Power Cords & Wiring Devices

Primary Power Components Division

A large selection of 2 and 3 conductor power cords and cord sets for North America, Argentina, Australia, Brazil, China, Continental Europe, Israel, Italy, Japan, Korea, South Africa, Switzerland, Taiwan, and the United Kingdom. The power cords are designed to comply with international safety agency regulations to insure safe and durable products. We have one of the largest selections of male plugs and female connectors in the industry available in various insulations, voltage ratings, colors, lengths, plugs, connectors, and shielding plus a full line of hospital grade and internationally certified power cords. Special power cords and strain relief configurations are available upon request. We also offer a wide range of Nema straight blade and twist-locking wiring device configurations available in plugs, connectors and receptacles with amp ratings of 15A, 20 & 30A, Industrial grade devices for rugged applications are designed for easy installation and UL listed with the highest regards for safety.



Power Supplies

Primary Power Components Division

Qualtek offers a wide range of AC/DC, DC/DC converters and LED power supplies. Qualtek power supplies are available in enclosed frame, open frame, L bracket, U bracket, external desktop, wall mounted, on board module and din rail. Our power supplies are offered in compact designs to comply with safety agency regulations and are available with power factor correction and multiple outputs.



Thermal Circuit Breakers

Primary Power Components Division

A diverse range of thermal circuit breakers. Qualtek's QLB and QMB series are compact and cost effective. The single pole, push to reset circuit breakers are designed to protect equipment. With a wide range of amp ratings from 3 - 40 amps.



International Procurement Services

International Procurement Services Division

The Qualtek Group is a global network with offices in China, Hong Kong, Mexico, Philippines, Taiwan and the USA with the resources and expertise to provide a complete range of offshore services from component sourcing to complete turnkey projects. We have locations in major manufacturing regions in the world; thus enabling us to have immediate access to the benefits of the newest technology, highest quality products and most cost effective production methods.



ISO 9001:2006
FS 515889

Qualtek Electronics Corporation

7675Jenther Dr. * Mentor, Ohio 44060 * USA
Telephone: 1-440-951-3300 * Fax: 1-440-951-7252
E-mail: mailbox@qualtekusa.com * Web: www.qualtekusa.com



PS-0500